

"SNAP ON"
FEATURE
TYP 3 PLCS
AT 120 DEG

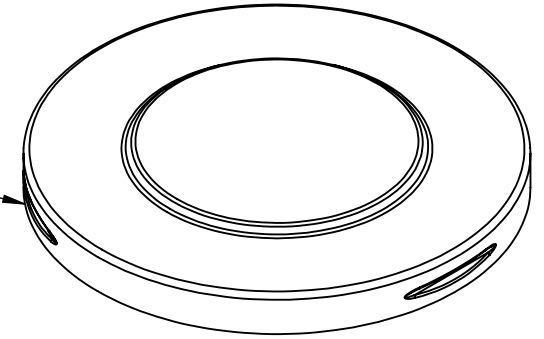

NOTES:

1. DRAWING SHOWS FINISHED MOLDED LID - TRIMMED
2. ALL EDGES HAVE RADII
3. HIDDEN LINES OMITTED FOR CLARITY
4. NOMINAL WALL THICKNESS 0.188
5. FOR ADDITIONAL DETAILS, REFER TO PART GEOMETRY

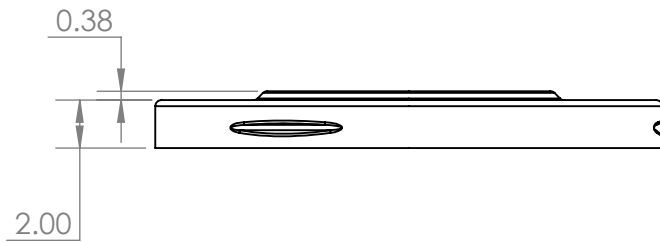

PROPRIETARY AND CONFIDENTIAL

THE INFORMATION CONTAINED IN THIS DRAWING IS THE SOLE PROPERTY OF REMCON PLASTICS INC. ANY REPRODUCTION IN PART OR AS A WHOLE WITHOUT THE WRITTEN PERMISSION OF REMCON PLASTICS INC. IS STRICTLY PROHIBITED.

		UNLESS OTHERWISE SPECIFIED:		NAME	DATE	Remcon Plastics Inc. 208 Chestnut Street, Reading Pa, 19602		
		DIMENSIONS ARE IN INCHES TOLERANCES: FRACTIONAL: N/A ANGULAR: $\pm 1/2$ deg DECIMAL: ± 0.020 in/in		DRAWN	PFE	5/26/11	TITLE: ND-35 SNAP ON LID	
				CHECKED	PFE	5/26/11		
				ENG APPR.	KM	5/26/11		
		ENGINEERING PROJECT #: 2114		COMMENTS:		SIZE	DWG. NO.	REV
		MATERIAL LLDPE				A	010201035002XXX	A
NEXT ASSY	USED ON	FINISH SMOOTH				SCALE: 1:8	WEIGHT:	SHEET 1 OF 1
APPLICATION		DO NOT SCALE DRAWING						